

BRISTAN

Installation Instructions and User Guide

Stratus Thermostatic Shower Valve

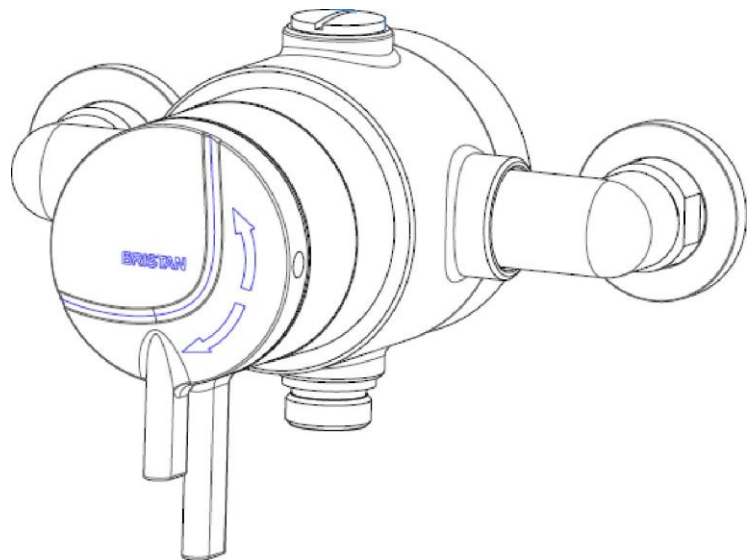

Models covered: STR TS1875 EDC C,
STR TS1875 CDC C

Please keep this booklet for future
Reference.

Installer, when you have read these
instructions please ensure you leave them
with the user.

Contents

Thank you for choosing Bristan, the UK's leading taps and showers expert. We have designed this product with your enjoyment in mind. To ensure that it works to its full potential, it needs to be fitted correctly. These fitting instructions have been created to give you all of the information you need and, if you need any further help, please do not hesitate to give us a call on 0844 701 6273.

Important Safety Information	3
General Information	4
Product Features	5
Specifications	6
Dimensions	7-8
Installation Requirements	9-11
Flow Regulators	12-13
Installation	14-17
Operation & Temperature Setting	18
Commissioning	19
In Service Testing	20-21
Maintenance	21-23
Troubleshooting	24-25
Guarantee	26-27
Service Policy	27

Important Safety Information

- Please read these instructions thoroughly and retain for future use.
- All products manufactured and supplied by Bristan are safe provided they are installed, used correctly and receive regular maintenance in accordance with these instructions.
- This fitting needs to be installed in accordance with, and meet the requirements of the Water Supply [Water Fittings] Regulations 1999 and Scottish Byelaws 2004.
- **If you are in any doubt about your ability to install this product safely you must employ the services of an experienced qualified plumber.**
- Do not use if the showerhead or shower hose has been damaged or is blocked.
- Do not crush or kink the shower hose, this could damage the hose and cause leaks.
- Remove all packaging and check the components for damage before starting installation.
- **& Warning:** Before starting any installation please consider the following: Prior to drilling into walls, check that there are no hidden electrical wires, cables or water supply pipes. This can be checked with the aid of an electronic detector.
- If power tools are used do not forget to:
 - Wear eye protection
 - Unplug equipment after use
- The fitting of isolating valves is required as close as is practical to the supply inlet feeds of the thermostatic mixing valve.
- The fitting of strainers is recommended as close as is practical to the water supply inlets of the thermostatic mixing valve.
- **& warning:** Before installing the new shower valve it is essential that you thoroughly flush through the pipework in order to remove any remaining swarf, solder, etc. Failure to carry out this procedure could cause problems or damage to the workings of the shower valve.
- This product **must not** be modified in any way as this will invalidate the guarantee.

General Information

This product has been tested to the TMV2 scheme which complies with the BS EN 1287:1999 [LP] and BS EN 1111:1999 [HPI thermostatic mixing valve standards and TMV3 approval for use in Healthcare and Commercial situations and performs to the requirements of NHS specification 008. It also satisfies the requirements of the Water Supply [Water Fittings) Regulations 1999 and current bylaws.

BS6700 recommends the temperature of stored water should never exceed 65°C. A stored water temperature of 60°C is considered sufficient to meet all normal requirements and will minimise the build up of lime scale in hard water areas.

If the fitting is installed at low pressure [tank fed). then the minimum distance from the highest installed position of the showerhead to the underside of the cold tank should be at least 1 metre to ensure adequate performance.

Note: Nominally equal [balanced) inlet supply pressures are recommended for optimum performance with mixer showers.

This shower valve should be installed in compliance with Water Regulations.

If in doubt, contact a registered plumber or you Local Water Authority or the Secretary of The Institute of Plumbing, address as follows;-

The Institute of Plumbing,
64 Station Lane,
Hornchurch,
Essex, RM 126NB
Tel: 01708 472791

Recommended Usage			
Domestic		Heavy Commercial	
Light Commercial		Health Care	

Product Features

1. On/Off Control

Turn the control anti-clockwise to turn the shower on and increase the flow of water.

Turn the control clockwise to decrease the flow of water and to turn the shower off_

2. Temperature Control

Turn the control anti-clockwise to increase the temperature.

Turn the control clockwise to decrease the temperature.

3. Shower Outlet

Connects the shower hose to the shower valve. If the top outlet is to be used, use the blanking plug to blank off the bottom outlet.

4. Isolation Elbows

Designed for ease of maintenance and servicing when the valve is installed in a wall cavity.

Supplied with STR TS1875 CDC Conly.

5. Concealing Shroud

Conceals exposed pipework which is shown when the valve is installed in a wall cavity.

Supplied with STR TS1875 CDC Conly.

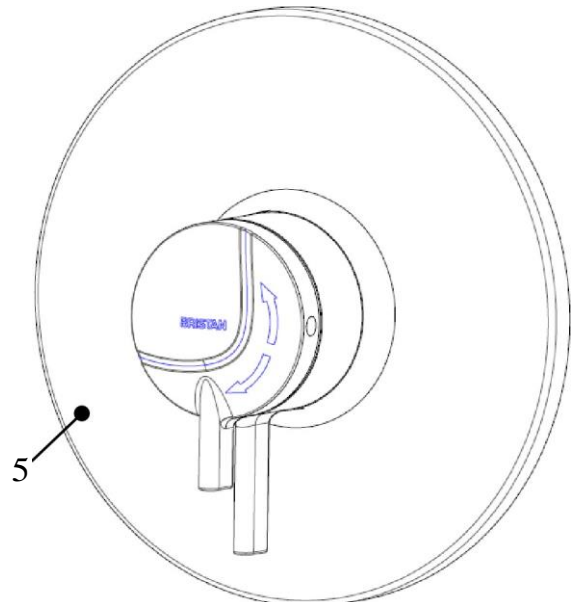
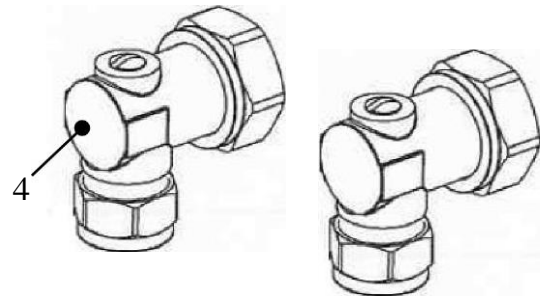
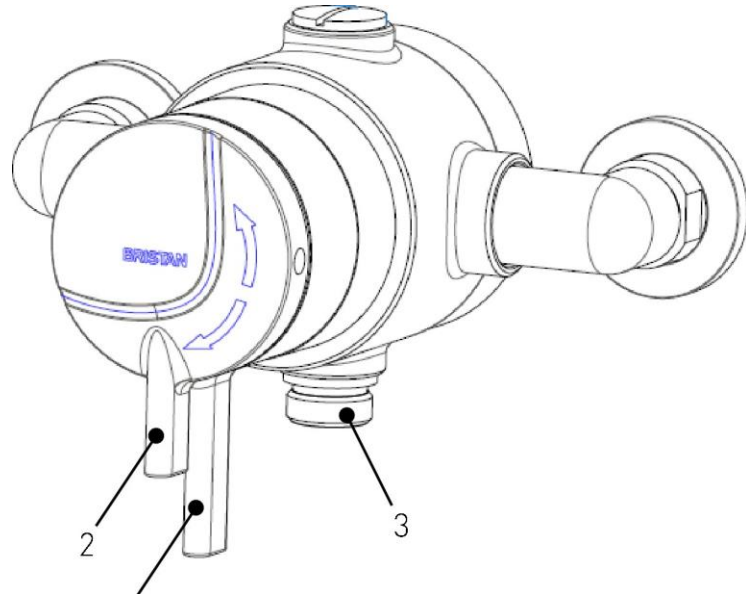

Specifications

Inlet Connections: 15mm compression connections.

STR TS1875 EDC C -148-158mm adjustable centres.

STR TS1875 CDC C - 175mm fixed centres.

Outlet Connections: Top or bottom G ½" BSP male 15mm compression adaptor.

Operating Pressure Range: Min: 0.1 bar- Max: 5.0 bar- Maximum recommended imbalance between hot and cold supply should not exceed a ratio of 5:1.

Maximum Static Pressure: 10.0 bar

Maximum Outlet Temperature: Factory pre-set to 43°C [can be re-set to suit site conditions). If the temperature is re-set to suit different site conditions the valve will work adequately however the TMV3 scheme will not apply.

Supply Requirements:

Minimum cold water supply temperature: 5°C.

Maximum cold water supply temperature: 25°C.

Maximum hot water supply temperature: 80°C.

[a maximum hot water supply temperature of 60 - 80°C is recommended for ablutionary purposes).

Note: The inlet hot water temperature must be at least 10°C above the required blend temperature [e.g. shower temperature 43°C: minimum hot supply 53°C.

Performance: [Open Outlet)

Flow Rates are in litres per minute at equal pressures

Pressure [bar)	0.1	0.2	0.4	0.6	0.8	1.0	1.5	2.0	3.0	4.0	5.0
Flow Rate	8.0	12	17	22	26	29	36	42	52	60	66

Dimensions Imm·sJ

STR TS1875 EDC C [Surface Mounted]

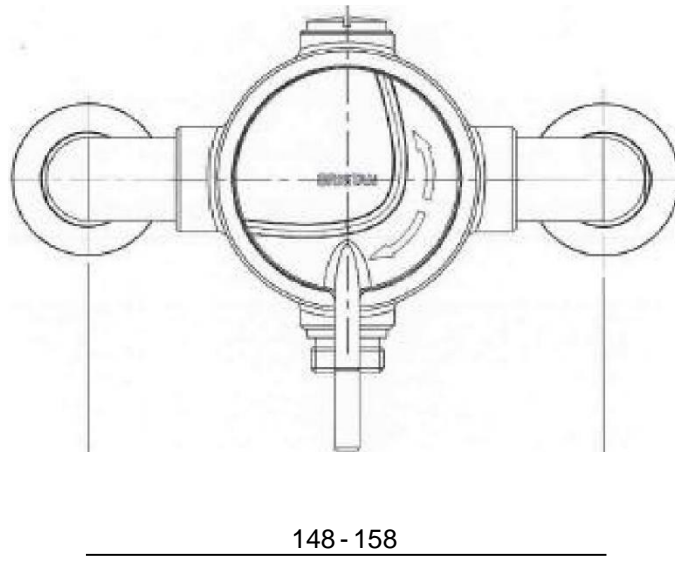
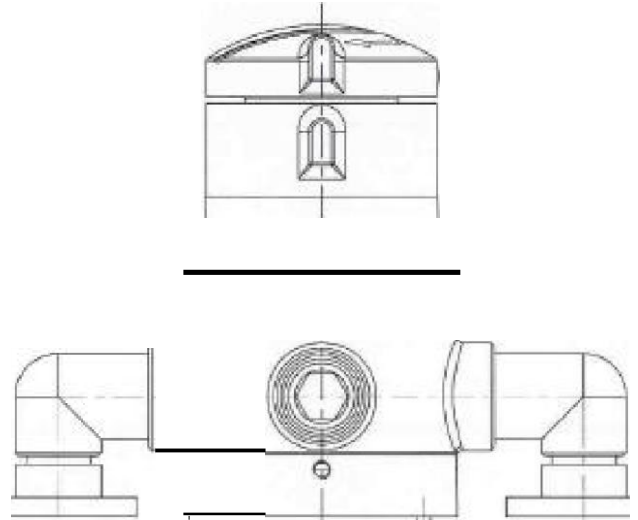
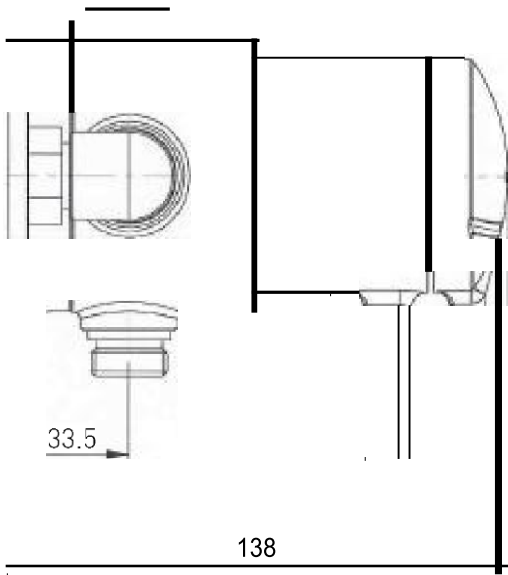

Dimensions 1mm·sJ

STR TS1875 CDC C [Concealed Model]

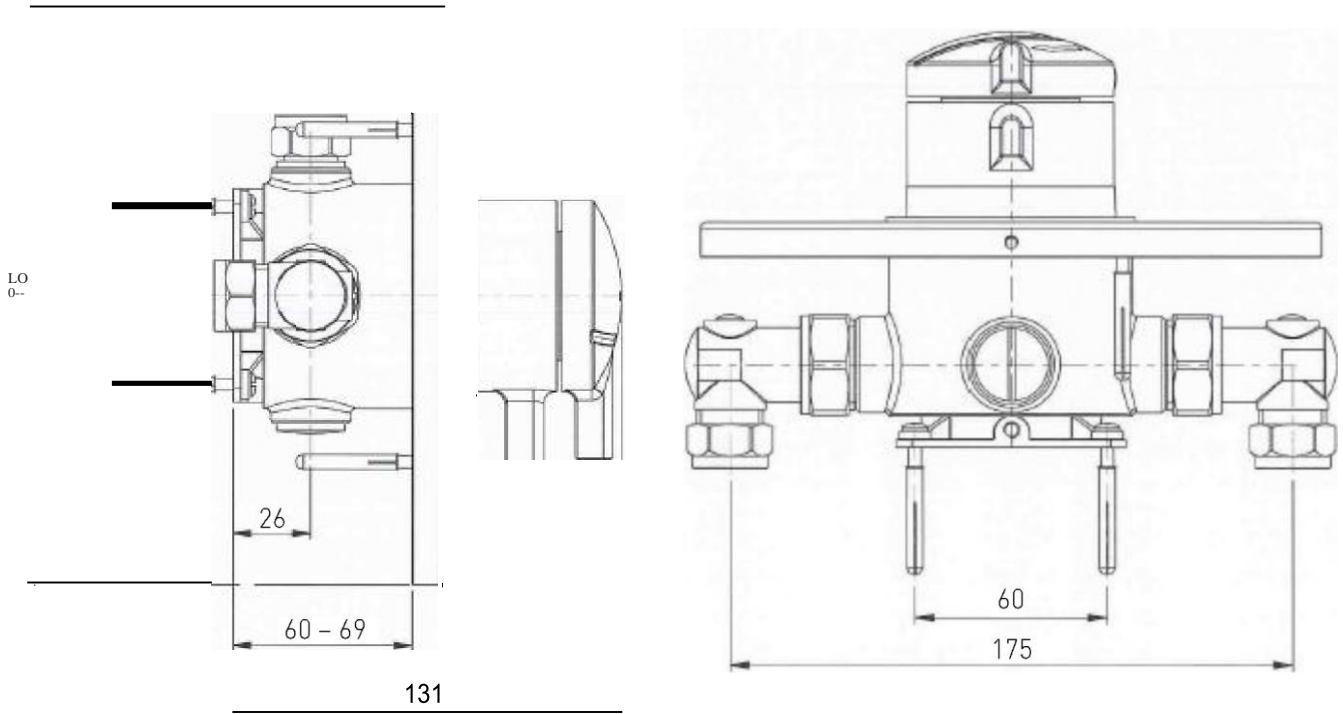

Suitable for wall cavity depths of between 60 - 69mm.

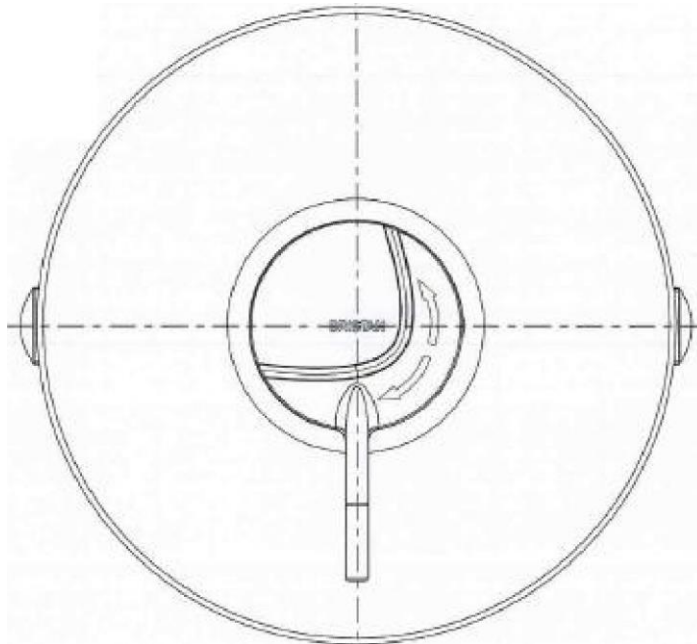

Installation Requirements

These fittings need to be installed in accordance with the following Installation Requirements and Notes [IRN] to ensure they meet the requirements of the Water Supply [Water Fittings] Regulations 1999 and the Scottish Byelaws 2004.

IRN R001: See text of entry for Installation Requirements or Notes.

IRN R040 - Schedule 2-15 [1]: The fitting shall be installed so that its outlet discharges above the spill-over level of any fixed appliance as indicated below:-

For backflow protection in domestic or installations up to, and including, Fluid Category 3.

If the fitting cannot be installed as indicated in the table opposite it shall be installed as either **a** or **b** below:

a: with an approved double check valve assembly or some other no less effective backflow prevention device immediately upstream of the inlet.

b: so that it draws water by gravity only from a cistern, or cylinder having a permanently open vent pipe, and the distributing pipe supplies no other fitting [other than draining tap] at a lower level.

For backflow protection in premises or installations up to, and including Fluid Category 5.

The vertical distance of the outlet above the spill-over level shall be not less than 20mm or twice the diameter of the inlet pipe to the fitting, whichever is the greater. If the fitting cannot be installed as indicated it shall be installed with a backflow prevention arrangement suitable for the Fluid Category.

Size of tap or combination fitting.	Vertical distance of outlet above spill-over level.
1. Not exceeding 1/2 in	20mm
2. Exceeding 1/2 in but not exceeding 3/4 in	25mm
3. Exceeding 3/4 in	70mm

Installation Requirements

Installation Requirements

Conditions of use for Type 2 [Thermostatic mixer] valves

	High Pressure	Low Pressure
Maximum Static Pressure [Bar]	1 0	1 0
Flow Pressure, Hot & Cold [Bar]	0.5 to 5	0.1 to 1.0
Hot Supply Temperature [°C]	55 to 65	55 to 65
Cold Supply Temperature [°C]	Equal to or less than 25	Equal to or less than 25

Note: Valves operating outside these conditions cannot be guaranteed by the Scheme to operate as Type 2 valves.

If a water supply is fed by gravity then the supply pressure should be verified to ensure the conditions of use are appropriate for the valve.

Recommended Outlet temperatures

The BuildCert TMV scheme recommends the following set maximum mixed water outlet temperatures for use in all premises:

41°C for showers;

The mixed water temperatures must never exceed 46°C.

The maximum mixed water temperature can be 2°C above the recommended maximum set outlet temperatures.

Note: 46°C is the maximum mixed water temperature from the bath tap. The maximum temperature takes account of the allowable temperature tolerances inherent in thermostatic mixing valves and temperature losses in metal baths.

& Warning: It is not a safe bathing temperature for adults or children.

The British Burns Association recommends 37 to 37.5°C as a comfortable bathing temperature for children. In premises covered by the Care Standards Act 2000, the maximum mixed water outlet temperature is 43°C.

The thermostatic mixing valve [TMV] will be installed in such a position that maintenance of the TMV and its valves and the commissioning and testing of the TMV can be undertaken.

The fitting of isolation valves is required as close as is practical to the water supply inlets of the thermostatic mixing valve.

Installation Requirements

Conditions of use for Type 3 [Thermostatic mixer] valves

In order to give compliance with N.H.S. specification 008 the table below lists the conditions for normal use. These valves will perform adequately outside these parameters, however they cannot be guaranteed by the scheme to operate as Type 3 valves. If they are required to work with other supply conditions an engineer must carry out a risk assessment and satisfy themselves that the valves are suitable for use.

Normal Conditions of Use for Type 3 valves

	High Pressure	Low Pressure
Maximum Static Pressure [Bar]	10	10
Flow Pressure, Hot & Cold [Bar]	1.0to5.0	0.2 to 1.0
Hot Supply Temperature [°C]	55 to 65	55 to 65
Cold Supply Temperature [°C]	5 - 20	5 - 20
Minimum Temperature Differential °C	10°C	10°C

This valve has been approved for use in the following designations.

Code	Operating Pressure	Application
HP-S	High Pressure	Shower
LP- SE	Low Pressure	Shower

Key:

HP - High Pressure **LP** - Low Pressure

The BuildCert TMV scheme recommends the following set maximum mixed water outlet temperatures for use in all premises:

41°C for showers;

The mixed water temperatures must never exceed 46°C.

The maximum mixed water temperature can be 2°C above the recommended maximum set outlet temperatures.

Note: For wash basins, washing under running water is assumed.

Flow Regulators

Cold Supply	Hot Supply	Fit to Elbows		Comments
		Cold	Hot	
0.1 to 1.0bar [1 to 10 MTR HEAD]	0.1-1.0 bar [1-10 MTR HEAD]	Nothing	Nothing	Max ratio of Hot - Cold pressure 1:5/5:1
1.0 to 5.0 bar [10-50 MTR HEAD]	1.0 -5.0 bar [10-50 MTR HEAD]	Green 7Litre Limiter	Yellow 5 Litre Limiter	This arrangement will also suit pumped systems#
Mains [1.5-10bar]	Gravity 0.1-0.2 bar [1-2 MTR HEAD]	White Orifice [No washer required]	Nothing	
	Gravity 0.2-0.5 bar [2-5 MTR HEAD]	Green 7 Litre Limiter	Nothing	
	Gravity 0.5 bar + [5 MTR HEAD]	Green 7 Litre Limiter	Yellow 5 Litre Limiter	
	Unvented hot water storage system [shower coil]			
	Cambi - boiler [Instantaneous water heater]	Green 7 Litre Limiter	Yellow 5 Litre Limiter*	Adjust Bottom Cap **[1/2 turn anti-clockwise]
	Electric Unvented *** Instantaneous Heated	Yellow 5 Litre Limiter	Nothing	Adjust Bottom Cap** [1/2 turn anti-clockwise]
	Any vented [open outlet] heater, gas or electric, e.g. normal' electric shower	Do not use with mixer valves - This would be extremely dangerous		

Flow Regulators

The table on page 12 shows the flow regulator requirements and valve adjustments for various hot/ cold supplies.

Flow limiters are fitted and will be required to be removed when installed in low pressure [gravity fed] applications below 1.0 bar. To remove: unscrew the retaining ring and remove limiter and washer. Re-fit elbows back to the body.

* With certain permutations of combi-boiler hot supply and cold supply, it must not be necessary to fit the yellow 5 litre flow limiter.

** The bottom cap is factory set at 3/4 turn from the fully closed position. Only adjust if instructed to do so in the table on page 11 or when fitting a replacement cartridge assembly. [See maintenance section

*** **& Important:** It is a requirement of Instantaneous Electric Water Heaters that a stable flow of water passes through the heater. This requirement can be satisfied by using a flow stabiliser in the supply to the heater. It should be adjusted to give a flow temperature of 45-50°C from the heater.

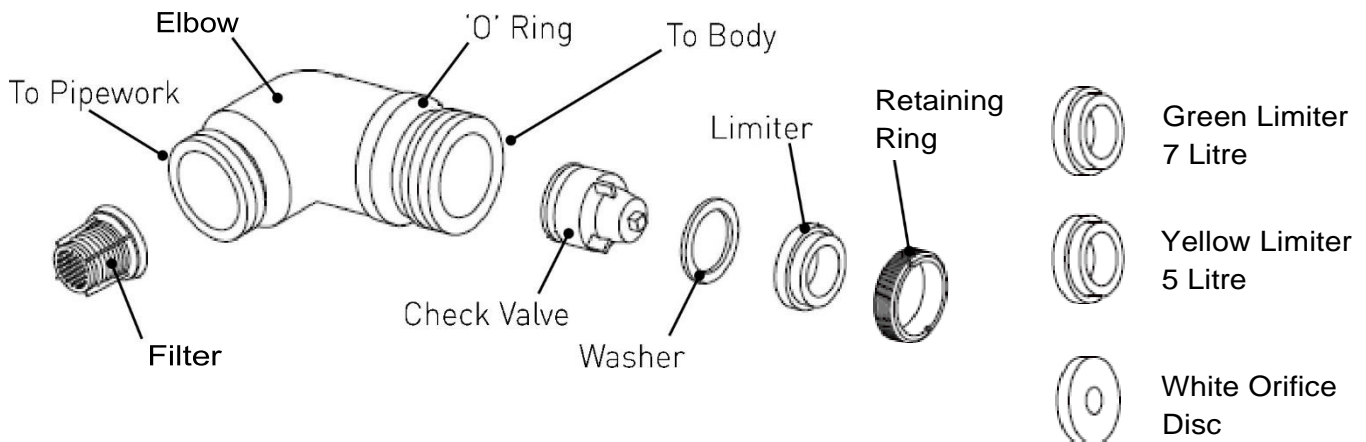

Installation

STR TS1875 EDC C [Surface Mounted]

Before Installation

Flush through the pipework to ensure removal of debris. Turn off the mains water supply and close any isolating valves.

1. Inlet positions

The shower valve has three inlet positions, top, bottom and rear. Rotate the inlet elbows as required.

With the elbows screwed fully against the valve body it can be unscrewed a maximum of 1.5 turns to allow for lateral tolerance.

Sufficient 15mm diameter supply pipes should protrude through the finished wall surface to fit fully into the shower valve elbows.

2. Attach backplate to wall

Loosen the 'backplate' grub screw on the backplate using a hexagonal key.

Use the backplate as a template and mark the centres of the fixing holes onto the wall.

& Warning: Please check for any hidden pipes and cables before drilling holes in the wall.

Drill suitable holes and insert the wall plugs. Securely attach the backplate to the wall using the screws provided.

Important: Water supplies to the mixer must be with hot on the left and cold on the right when views from the front.

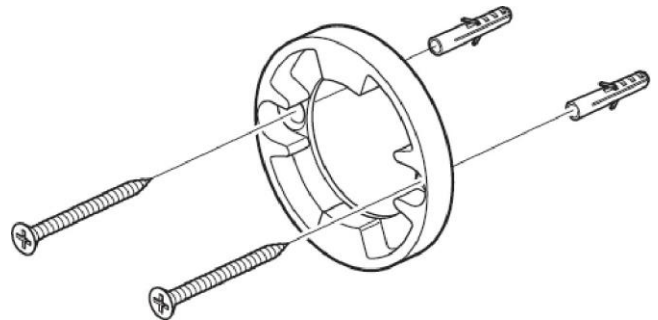
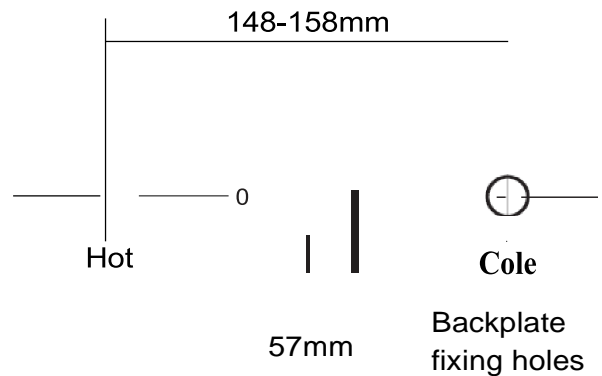

Installation cont.

STR TS1875 EDC C [Surface Mounted] continued.

3. Attach shower valve

Place the shrouds over the water supply pipes. Insert the 15mm hot and cold water supply pipes into the inlet connections and tighten the nuts. Ensure the olives and filter are in place.

Secure the shower valve to the backplate  by tightening the backplate grub screw.

Re-attach the shower valve to the backplate by tightening the grub screw.

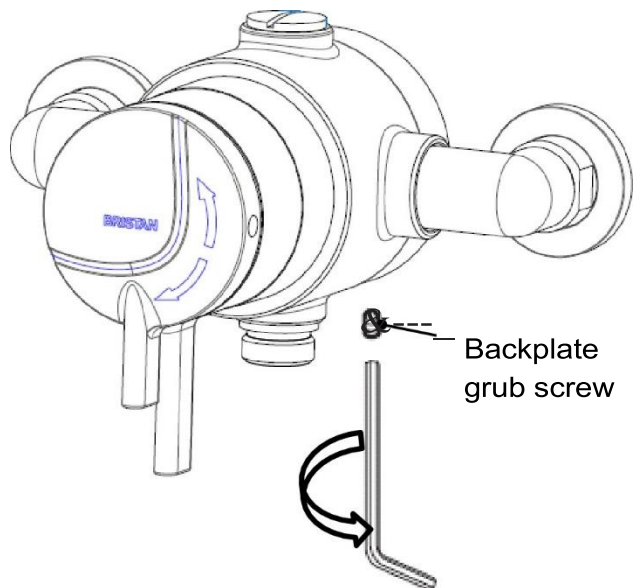
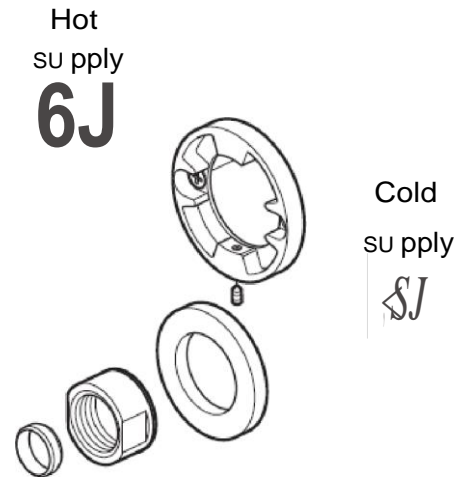

Installation cont.

STR TS1875 CDC C [Concealed]

Before Installation

Flush through the pipework to ensure removal of debris. Turn off the mains water supply and close any isolating valves.

Important: It is essential when installing this shower valve full access is made available for future servicing purposes.

1. Inlet positions

The shower valve has three inlet positions - top, bottom and rear. Rotate the inlet

elbows as required.

Once the required position of the inlet supply has been identified sufficient 15mm diameter supply pipes should protrude through the finished wall surface with 175mm between centres to fit fully into the shower valve elbows.

2. Attach backplate to wall

Using the backplate as a template mark the centres of the fixing holes onto the wall.

& Warning: Please check for any hidden pipes and cables before drilling holes in the wall.

Drill suitable holes and insert the wall plugs. Securely attach the backplate to the wall using the screws provided.

Important: Water supplies to the mixer must be with hot on the left and cold on the right when views from the front.

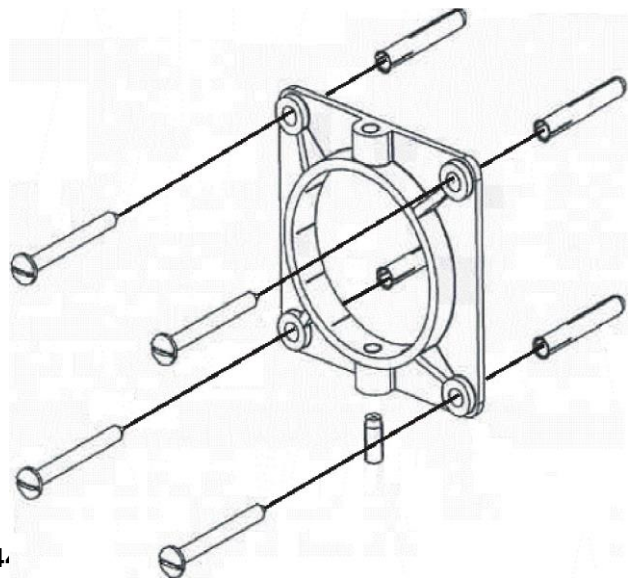
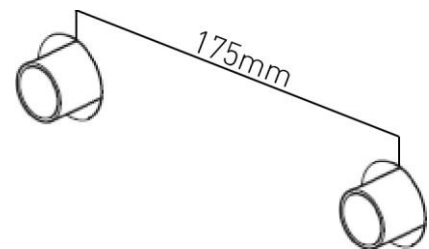
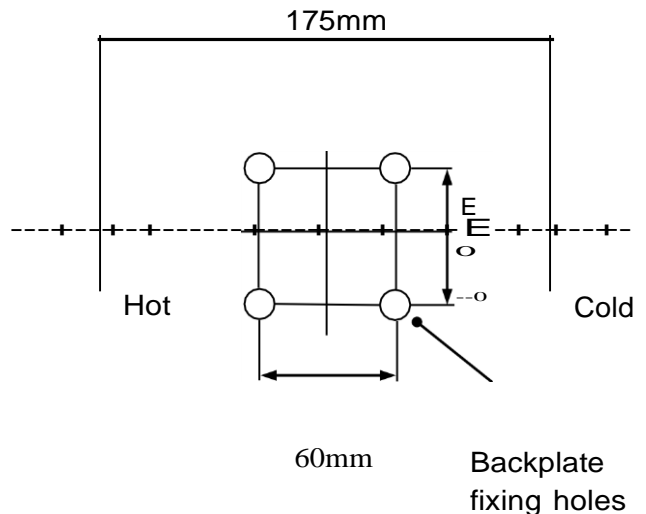

Installation cont.

STR TS1875 CDC C (Concealed) continued.

3. Attach isolation elbows to mixer valve

This valve is supplied with isolation elbows which need to be fitted as shown opposite.

With the elbows screwed fully against the valve body it can be unscrewed a maximum of 1.5 turns to allow for lateral tolerance.

4. Attach the shower valve

Insert the 15mm hot and cold water supply pipes into the inlet connections and tighten the nuts. Ensure the olives and filter are in place.

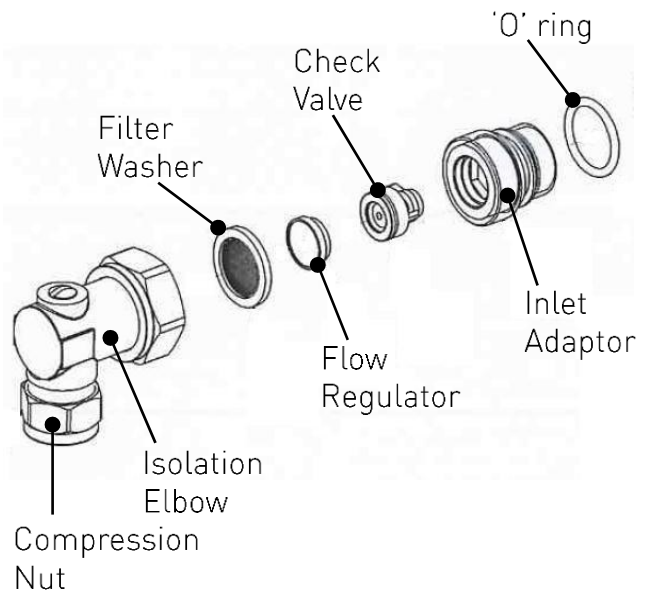

Secure the shower valve to the backplate by tightening the backplate grub screws.

5. Fit the concealing plate

Once the valve is installed into position within the wall cavity screw the concealing plate fixing onto the finished wall surface using the fixings supplied.

Slide the concealing plate over the sleeve of the valve until firmly against the wall surface ensuring the concealing seal is fitted between the concealing plate and the concealing plate fixing.

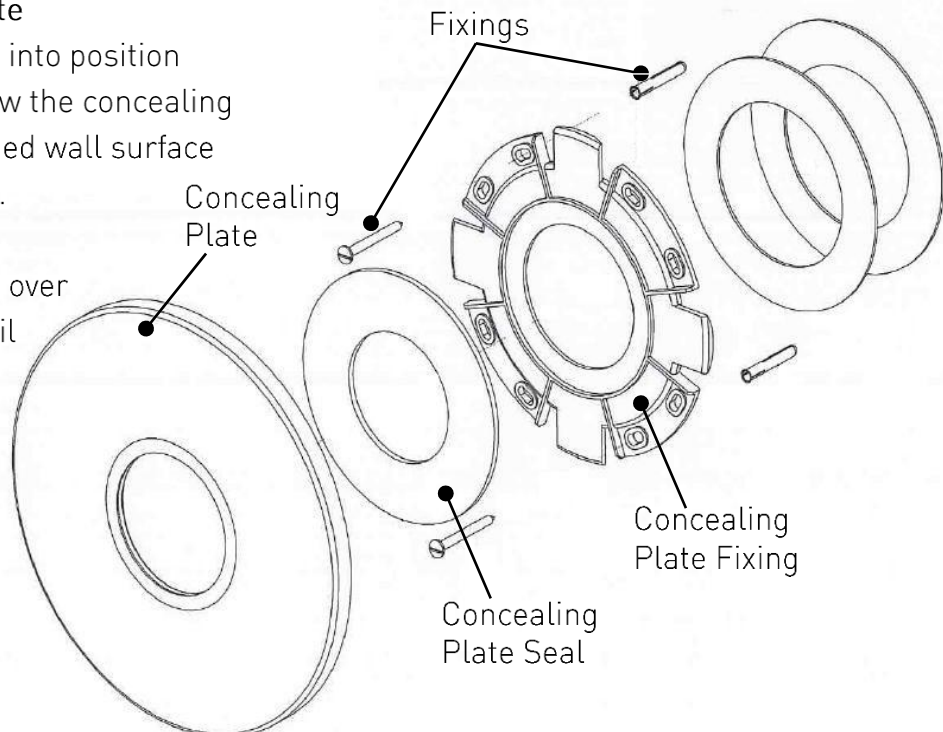

Operation & Temperature Setting

1. On/Off Control

Turn the control [1] anti-clockwise to turn the shower on and increase the flow of water.

Turn the control [1] clockwise to decrease the flow of water and to turn the shower off_

2. Temperature Control

Turn the control [2] anti-clockwise to increase the temperature.

Turn the control [2] clockwise to decrease the temperature.

The maximum temperature is factory set to 43°C however this can be adjusted to suit different site conditions [see below to re-set maximum temperature setting).

Maximum Temperature Setting

The maximum blend temperature should be limited to ensure that no undesirable temperature is obtained. If adjustment is necessary the following should be carried out:

- Turn the controls [1 & 2) anti-clockwise so the shower is running at full flow and is at the maximum temperature [allow the flow/temperature to stabilise for a few minutes).
- Prise out the cap on the side of the temperature handle control. Remove the grub screw and pull the handle off.
- Turn the spindle anti-clockwise for a warmer temperature and clockwise for a cooler temperature.

- When the desired maximum temperature is achieved replace the spindle screw and push the handle back onto the cartridge spindle. Replace the grub screw and cap.

STR TS1875 EDC C shown below

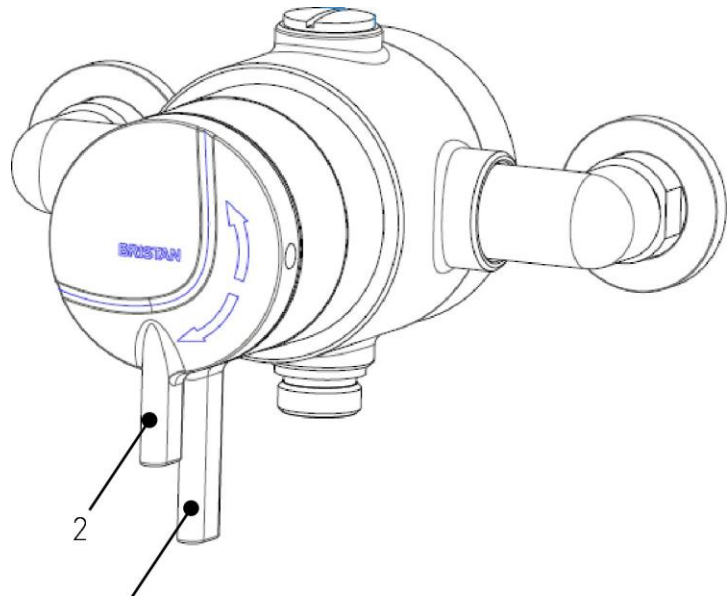

Commissioning

Commissioning notes for Thermostatic Mixing Valves

The first step in commissioning a thermostatic mixing valve is to check the following:

1. The designation of the thermostatic mixing valve matches the intended application.
2. The supply pressures are within the range of operating pressures for the designation of the valve.
3. The supply temperatures are within the range permitted for the valve and by guidance information on the prevention of legionella etc.
4. Isolating valves [and strainers preferred] are provided.

If all these conditions are met, proceed to set the temperature as stipulated in the maintenance section.

The mixed water temperature at the terminal fitting must never exceed 46°C.

It is a requirement that all TMV3 approved valves shall be verified against the original set temperature results once a year. When commissioning/ testing is due the following performance checks shall be carried out:

- Measure the mixed water temperature at the outlet.
- Carry out the cold water supply isolation test by isolating the cold water supply to the TMV [Thermostatic Mixer Valve].

wait for five seconds, if the water is still flowing check that the temperature is below 46°C.

If there is no significant change to the set temperature [$\pm 2^{\circ}\text{C}$ or less change from the original settings] and the fail-safe shut off is functioning, then the valve is working correctly and no further service work is required.

Notes: If there is a residual flow during the commissioning or the annual verification [cold water supply isolation test], then this is acceptable providing the temperature of the water seeping from the valve is no more than 2°C above the designated maximum mixed water outlet temperature setting of the valve.

Temperature readings should be taken at the normal flow rate after allowing for the system to stabilise.

The sensing part of the thermometer probe must be fully submerged in the water that is to be tested.

Any TMV that has been adjusted or serviced must be re-commissioned and re-tested in accordance with the instructions in the maintenance section.

The installation of thermostatic mixing valves must comply with the requirements of the Water Supply [Water Fittings] Regulations 1999.

In Service Testing

Purpose

The purpose of in service tests is to regularly monitor and record the performance of the thermostatic mixing valve.

Deterioration in performance can indicate the need for service work on the valve and/or water supplies.

Procedure

Using the same measuring equipment or equipment to the same specification as used in the commissioning section, adjust the temperature of the mixed water in accordance with the manufactures instructions and the requirement of the application. Carry out the following sequence:

- a) Record the temperature of the hot and cold water supplies.
- b) Record the temperature of the mixed water at the largest draw-off flow rate.
- c) Record the temperature of the mixed water at a smaller draw-off flow rate, which shall be measured.

If the mixed water temperature has changed significantly from the previous test results [e.g. > 1 K], record the change and before re-adjusting the mixed water temperature check:

- a) That any in-line or integral strainers are clean.
- b) Any in-line or integral check valves or other anti-back siphonage devices are in good working order.

c) Any isolating valves are fully open.

With an acceptable mixed water temperature, complete the following procedure:

- a) Record the temperature of the hot and cold water supplies.
- b) Record the temperature of the mixed water at the largest draw-off flow rate
- c) Record the temperature of the mixed water at a smaller draw-off flow rate, which shall be measured.
- d) Isolate the cold water supply to the mixing valve and monitor the mixed water temperature.
- e) Record the maximum temperature achieved as a result of [d] and the final stabilised temperature.
- f) Record the equipment, thermometer etc. used for the measurements.

If at step [e] the final mixed water temperature is greater than the values in table 17 and/ or the maximum temperature exceeds the corresponding value from the previous results by more than about 2 K, the need for service work is indicated.

Note: In-service tests should be carried out with a frequency, which identifies a need for service work before an unsafe water temperature can result. In the absence of any other instruction or guidance, the procedure described in Annex F of D 08 may be used.

In Service Testing & Maintenance

Annex F of D 08 [informative)

Frequency of in-service tests

General

In the absence of any other instruction or guidance on the means of determining the appropriate frequency of in-service testing, the following procedure may be used:

a) 6 to 8 weeks after commissioning carry out the tests in 'In-Service Tests'.

b) 12 to 15 weeks after commissioning carry out the tests detailed in 'In-Service Tests'.

Depending on the results of the above tests, several possibilities exist:

a) If no significant changes [e.g. < 1 KI in mixed water temperatures are recorded between commissioning and 6 to 8 week testing, or between commissioning and 12 to 15 week testing the next in-service test can be deferred to 24 to 28 weeks after commissioning.

b) If small changes [e.g. 1 to 2 KI in mixed water temperatures are recorded in only one of these periods, necessitating adjustment of the mixed water temperature, then the next in-service test can be deferred to 24 to 28 weeks after commissioning.

c) If small changes [e.g. 1 to 2 KI in mixed water temperatures are recorded in both of these periods, necessitating adjustment of the mixed water temperature, then the next in-service test should be carried out at 18 to 21 weeks after commissioning.

test should be carried out at 18 to 21 weeks after commissioning.

d) If significant changes [e.g. > 2 KI in mixed water temperatures are recorded in either of these periods, necessitating service work, then the next in-service test should be carried out at 18 to 21 weeks after commissioning.

General Cleaning

Your fitting has a high quality finish and should be treated with care to preserve the visible surfaces. All finishes will wear if not cleaned correctly. The only safe way to clean your product is to wipe with a soft damp cloth. Stains can be removed using washing up liquid. All bathroom cleaning products [powders and liquids] will damage the surface of your fitting, even the non-scratch cleaners.

Note: Never use abrasive detergents or disinfectants or those containing alcohol, hydrochloric acid or phosphoric acid.



Bristan recommend E-cloth for cleaning all of our bathroom & kitchen products. Using just water, E-cloth gives a smear

free, deep clean by breaking up and hold dirt, which normal cloths leave behind. Order through your Bristan stockist [order code: ECLOTHI.

In Service Testing & Maintenance

Need help? Give us a call on **0844 701 6273** and speak to one of our trained advisors. _____

Servicing

If your thermostatic mixer valve fails to operate correctly it could be the result of an incorrect installation. Please refer to the installation section & site requirements.

If the valve has operated correctly for some time, but no longer performs acceptably, you may find it useful to firstly refer to the fault diagnosis in the Troubleshooting section.

Should the valve require servicing the following procedure should be followed.

- Isolate both hot and cold supplies to the shower valve by either:
 - Turning the water supply off at the mains stopcock or
 - Turning off the isolation valves to the shower valve.
- Prise out the cap on the side of the temperature handle and remove the grub screw. Pull the handle off from the spindle adaptor.
- Remove the centre screw and spindle adaptor.
- Pull the temperature stop plate off and remove the flow handle off from the cartridge.
- Remove the sleeve from the shower valve body remembering the position in which it is removed.

- Using a suitable spanner unscrew the large brass nut from the body to remove the cartridge.

- Once the cartridge has been removed it will expose the piston and thermostat assembly which also needs to be removed from the shower valve.

Cartridge Dis-assembly

- Remove the circlip situated between the top of the brass nut and the bottom of the exposed spindle.

- Once the circlip has been removed push the top of the spindle through the brass nut to expose the cartridge assembly. There is an **•O•** ring on the inside of the large nut which needs to be replaced when servicing the cartridge.

- Unscrew the half cartridge [bottom section of the cartridge] by inserting a flat tool into the slots and a suitable spanner onto the hexagonal part of the cartridge head and unscrew. The half cartridge has a standard right hand thread.

- Remove the circlip and push the spindle assembly out of the spindle housing.

- Remove all **•O•** rings and washers from the spindle, spindle housing and cartridge.

Maintenance cont.

Soak all metal parts including the piston, thermostat and spring in a 50/50 solution of hot water and white vinegar and allow to soak for a couple of hours. If heavily scaled allow to soak overnight.

Re-assembly

- Replace all •O• rings and washers. A maintenance kit is available for you mixer valve.

Please visit:

www.bristan.com/sparesfinder in order to find spare parts for this product.

- Grease all •O• rings and seals. Only use a silicone based grease [light smear only]. Grease the thread of the spindle and the spindle housing.
- Add P.T.F.E washer to the spindle from the splined end then the •O• ring. The spindle is then screwed into the spindle housing. Locate the spindle assembly into the head and re-fit the circlip.
- Screw the head assembly onto the half cartridge and tighten fully by inserting a flat tool into the slots and use a suitable spanner on the hexagonal part of the head and tighten.
- Place the thermostat into the piston [black wax end pointing upwards) and place the spring into the recess in the bottom of the piston.

Tip: Add a dab of grease to the end of the spring to keep it in place while assembling it with the piston and cartridge.

- Offer the piston and thermostat assembly up to the bottom of the cartridge assembly.

Screw the complete assembly into the valve body. Do not adjust the bottom cap unless you are installing a new cartridge. If a new cartridge is being fitted screw the bottom cap fully clockwise until it stops, then unscrew anti-clockwise 3/4 of a turn only, then refer to the flow regulator table on page 12 to see if any further adjustments are required for your particular system.

- Replace the sleeve in the same position which it was removed and push the flow handle back onto the cartridge. Replace the circlip to hold the flow handle in position.
- Fit the temperature stop plate in the same position to which it was removed. Push the spindle adaptor on to the cartridge spindle and replace the centre screw.
- Push the temperature handle onto the spindle adaptor, tighten the grub screw and push fit the cover cap back on to the handle.

Once any maintenance has been completed refer to the maximum temperature setting on page 18.

Troubleshooting

Symptom	Cause	Remedy
Maximum water temperature too hot or cold	Maximum water temperature set incorrectly.	Reset maximum water temperature. Refer to 'Maximum Temperature Setting' in Commissioning section [page 19] and 'Adjusting the Temperature' in Operation & Temperature setting section [page 18]
Outlet water temperature too hot/cold.	Inlet filter is partially blocked.	Check insert filters for any blockages and clean as necessary.
	Installation conditions outside operating parameters.	Refer to Installation Requirements section [page 9-11]. Service shower valve as recommended. Refer to Maintenance section [pages 21-23] Refer to Operation & Temperature Setting section [page 18].
Water temperature too cold - maximum water temperature incorrectly set.	Hot water temperature is less than 10°C above the required blend temperature.	Adjust hot water temperature or wait for water system to reheat if stored system is used.
	Instantaneous water heater not igniting because water flow rate is too low.	Increase water flow rate through the system. Check cartridge inlet filters and clean or replace. Refer to Maintenance section [pages 21-23]. Contact the boiler manufacturer.
	Instantaneous water heater not igniting because water pressure is too low.	Increase water pressure through system. Contact the boiler manufacturer.

Troubleshooting

Symptom	Cause	Remedy
Only hot or cold water from shower valve outlet.	Inlet water supplies are reversed [hot to cold supply).	Check the connections are the correct way round. Hot on the left and cold on the right when viewed from the front. Rework pipework as necessary.
	Inlet filter is partially blocked.	Clean or replace, flush through pipework before refitting.
No flow when shower is turned on.	Inlet filter is partially blocked.	Check insert filters for any blockages and clean as necessary.
	Blocked or damaged check valve.	Remove check valve and clean/replace if necessary.
	Air block in either/ both supplies	Flush through supply pipework.
	Piston sticking	Remove thermostatic cartridge and piston. Service shower valve. Refer to Maintenance section [pages 21-23).
Pulsating flow and/ or varying temperature.	Air block in either/ both supplies	Flush through supply pipework.
	Incorrect use of flow regulators	Check and remove/ replace if necessary.
Flow rate too great	Flow regulators not fitted.	Fit flow regulators.
Shower valve will not shut off_	Thermostatic cartridge not shutting off fully.	Service shower valve. Refer to Maintenance section [pages 21-23]
Fail safe not working.	Shower valve requires commissioning.	Refer to Commissioning section [page 19).

Guarantee

Bristan offers solid guarantees to provide you with complete peace of mind.

Taps and Mixers

5 year parts and 1 year labour*.

Gold, painted and special finishes

3 years parts only.

All subject to proof of purchase.

Mixer Shower Valves

1 year parts. 1 year labour* [subject to registration]. or 1 year with proof of purchase.

Gold, painted and special finishes 3 years parts only.

Pumps and Power Showers

2 year parts. 1 year labour* [subject to registration].

Electric Showers/Instantaneous Water Heaters

2 year parts. 1 year labour* [subject to registration].

Accessories

5 year parts only. Includes bathrooms accessories, shower accessories [e.g. hoses, handsets and poles]. wastes, WC levers and light pulls. Gold, painted and special finishes 3 years parts only.

Sanitaryware

5 year parts only. Subject to proof of purchase.

Shower Enclosures and Shower Trays

10 year parts [subject to registration]. or 2 years with proof of purchase. 1 year labour* [subject to registration]. or 1 year with proof of purchase.

Heated Towel Rails

5 year parts only. Gold, painted and special finishes 3 years parts only. All subject to proof of purchase.

*Labour provided by an approved Bristan engineer. Guarantee only applies to products with a manufacturing fault. A deferred payment will be necessary in order to secure any visits by our engineers which will be charged if the problem is found **not** to be a manufacturing fault. If the fault is found to be down to a manufacturing error, the payment will be released and not charged.

This guarantee applies to products purchased within the United Kingdom or Republic of Ireland, but does not apply to products used commercially.

The guarantee is only available to original purchasers who have proof of purchase.

The installation must allow ready access to all products for the purpose of inspection, maintenance or replacement.

Any part found to be defective during the above guarantee period will be replaced without charge, providing that the product has been installed in accordance with the instructions, used as intended, and regularly serviced.

Servicing should be carried out at regular intervals of no more than 12 months and more frequently in hard water areas [heavy lime scale) areas.

In the unlikely event that any problems are encountered with the product's performance on installation, you must obtain guidance/authorisation from our Customer Service Department, and be able to supply proof and date of purchase, before any remedial action is taken.

The guarantee excludes general wear and tear and damage caused by accident, misuse or neglect, and does not cover the following:

Guarantee & Service Policy

- Components that are subject to general wear and tear such as filters, seals, O-rings and washers etc.
- Damage caused by faulty installation
- Damage caused by lime scale or any waterborne debris
- Damage caused by inappropriate cleaning products [see cleaning section]
- Damage caused by the use of non-Bristan parts
- The product being used for a purpose other than intended by the manufacturer.

In the interests of continuous product improvement Bristan reserves the right to alter specification as necessary.

Replacement Parts Policy

Important:

In the event of product or component malfunction, DO NOT tamper with or remove the product from site. Telephone the Customer Services Department and be prepared with the date of purchase, model number and a clear description of the complaint.

Our service staff are fully qualified to advise on correct installation procedures and will be able to diagnose whether the fault will require a replacement part or a visit from a Bristan engineer.

If required, a service call will be booked and either yourself or an appointed representative [who should be a person of 18 years or over] must be present during the visit.

All site visits to products out of guarantee will be carried out free of any parts or labour charges provided the conditions of the guarantee have been adhered to [the 2nd to 5th year of the guarantee is parts only, unless registered].

All site visits to products out of guarantee will be subject to charges for parts and labour. Charges will also be levied on cancelled appointments, unless advised to Bristan at least 24 hours in advance of the agreed date and time.

Should a product be discontinued, Spare parts stocks will be maintained, but in the event of a part becoming unavailable Bristan reserve the right to supply a substitute of equal quality.

In order to log an enquiry with us please visit <http://www.bristan.com/customerservice>

Please visit: www.bristan.com/sparesfinder in order to find spare parts for this product.

Opening times: Please refer to the Bristan website.

Customer Service: **Tel: 0844 701 6273 • Fax: 0844 701 6275**

Part Number: 800449
Issue: FI Stratus Range D6

BRISTAN

Bristan Group Ltd.

Birch Coppice Business Park

Dardon

Tamworth

Staffordshire

B78 1SG

Web: www.bristan.com

Email: enquire@bristan.com

A Masco Company